

Pneumatic Jolt Squeeze Moulding Machine

Since 1994

KELSONS®

When You Think Foundry.....Think KELSONS



SALIENT FEATURES

- STURDY CONSTRUCTION
- SPARE PARTS AVAILABLE
- EASY TO OPERATE
- HIGH PRODUCTION & LOW MAINTENANCE
- PARTS OF S. G. IRON & FG - 260 GRADE

Leading Manufacturers & Exporters of Full Range of Foundry Equipment,
Foundry Sand Testing Equipment, Foundry Metal Testing Equipment & Supplying Resin Coating Sand

KELSONS ENGINEERS AND FABRICATORS

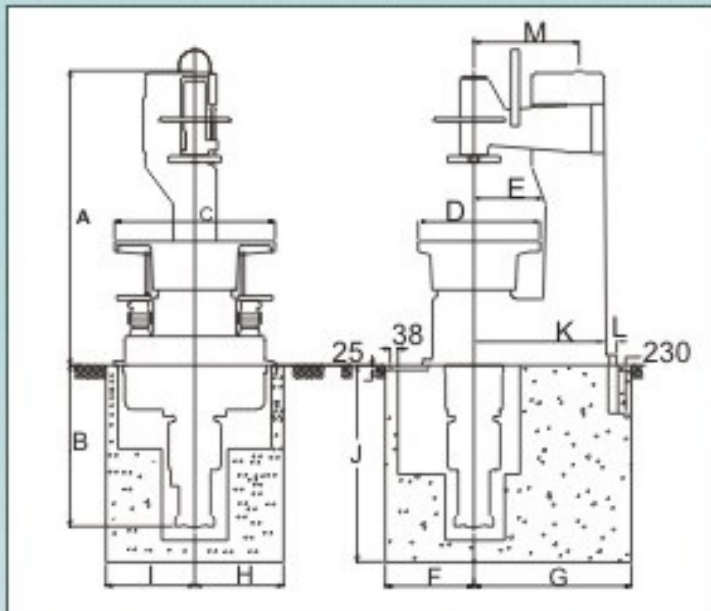

Plot No. E-22, 23 & 26, MIDC, Shirol, Kolhapur - 416 122.
Maharashtra. (INDIA)

Ph. : +91(0230) 2460156. FAX:+91(0230)2460543

E-mail:sales@kelsonsgroup.com Website:www.kelsonsgroup.com

Over All Dimensions [mm] In KPL Range

TYPE	A	B	C	D	E	F	G	H	I	J	K	L	M
KPL-2	1425	780	755	540	360	510	790	455	455	960	660	50	510
KPL-3	1790	950	975	640	375	640	1020	610	610	1200	780	90	590

TECHNICAL DATA

Jolt Capacity # Kgs

KPL-2

280

KPL-3

350

Squeeze Force # Kgs

5000

7200

Pattern Drawn MM [In]

205 [8"]

260 [10"]

Table Sizes MM [In]

750 X 535 [29.5" X 21"]

966 X 635 [38" X 25"]

Max. Size Of Mould Box
Used MM [In]*

640 X 580 [25" X 22½"]

850 X 635 [33.5" X 25"]

Min. Size Of Mould Box
Used MM [In]*

360 X 285 [14" X 11"]

530 X 330 [21" X 13"]

Max. height Table to Sq-Plate
MM [In]

390 [15"]

510 [20"]

Squeeze Plate adjustment
MM [In]

203 [8"]

200 [8"]

Squeeze stroke [MM]

76 [3"]

100 [4"]

Table height from floor [MM]

600 [23½"]

635 [25"]

Free Air Capacity pre cycle M³

0.35

0.41

Note - * These are outside dimensions of moulding box |# At 6.3 Kg/cm² air pressure [Kgs] |# All above given Dimensions are approximate.

Our Full Range of Products

Foundry Equipment : Sand Muller, Siever, Moulding M/c., Sand Mixer, Sand Drier, Cold Box Core Shooter, Shell Core Shooter, Resin Coating Plant, Core Oven, Cupola Charger, Ladle, Knock Out M/c., Shot Blast M/c., Grinder.

Sand Plant Product : Intensive Mixer, Inline Knock Out, Polygonal Siever, Sand Cooler, Belt Conveyor, Slat Conveyor, Bucket Elevator, Screw Feeder, Storage Hopper, Ploughs, Cast Iron Moulding Box, Pallet Car, Transfer Trolleys, Mould Pusher, Ladle Handler.

Kelsons reserves the right to change above specifications without prior intimation.